

DE-91 SEPARATOR DUNNAGE
1.25" INDEX
.25" POCKET

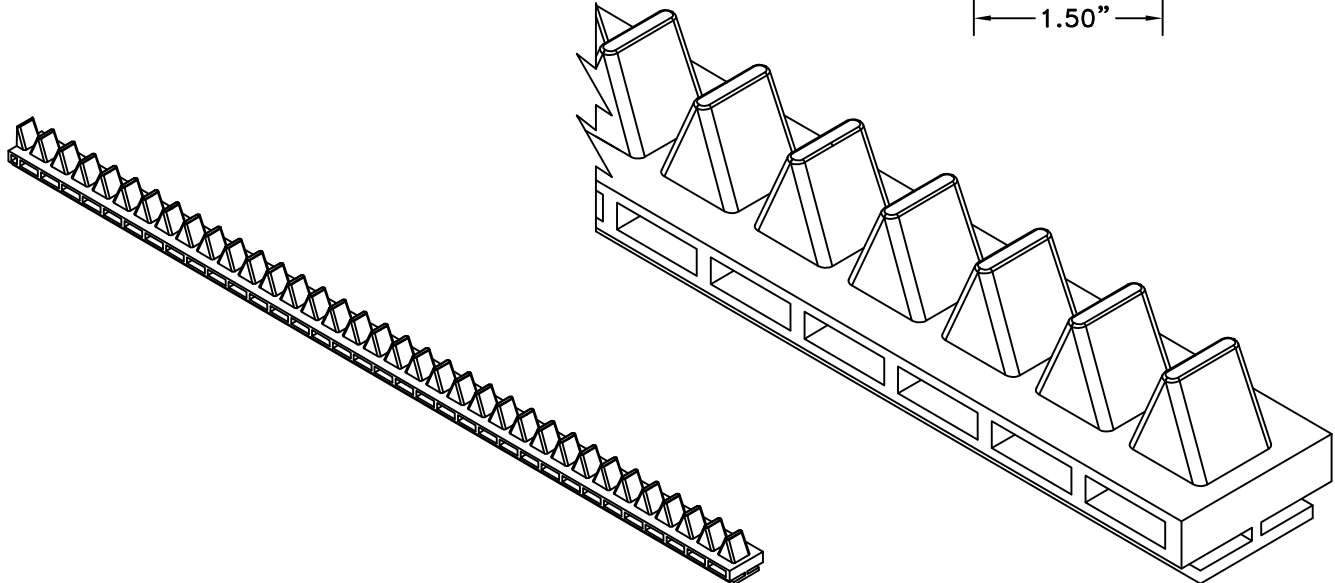
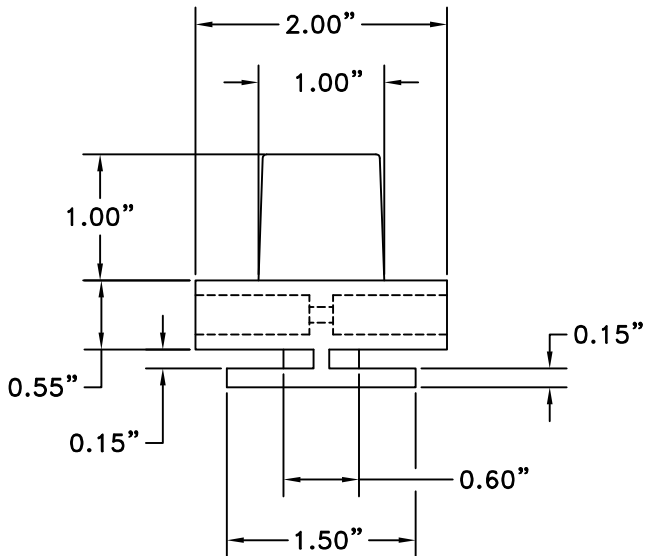
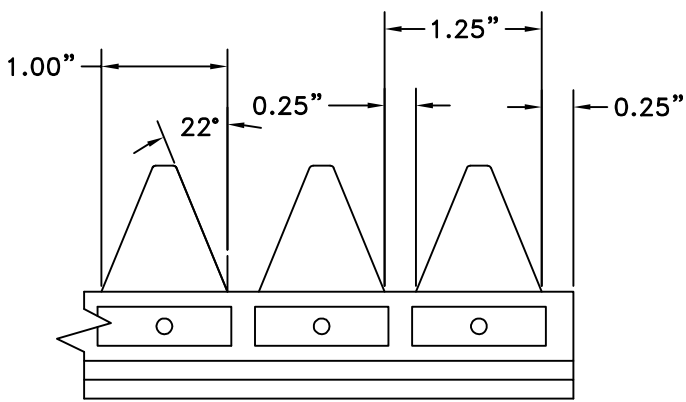
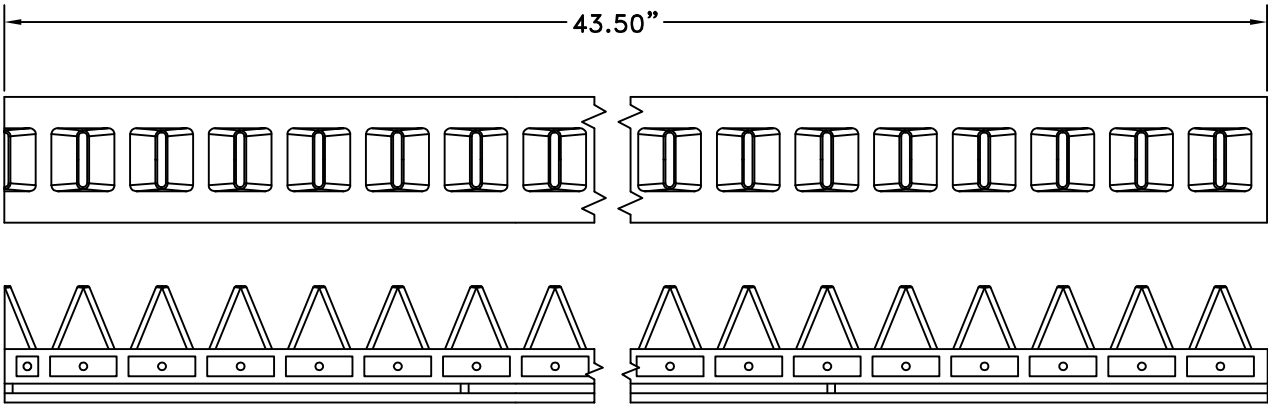

MATERIAL TYPE Thermoplastic Elastomer (T.P.E.)
HARDNESS (SHORE A) 90, CALL
COLOR BLACK, CALL

1.25" Index .25" Pocket

Applications:
 - Part Separation



Dunnage Engineering
 Brighton, Michigan

800-443-5553 www.dunnage-eng.com