

# 1.50" Dia. TPU Snap-in Button DE1129

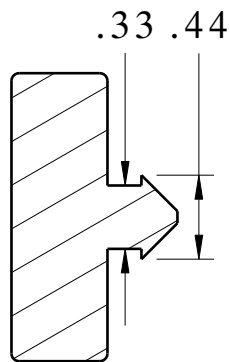
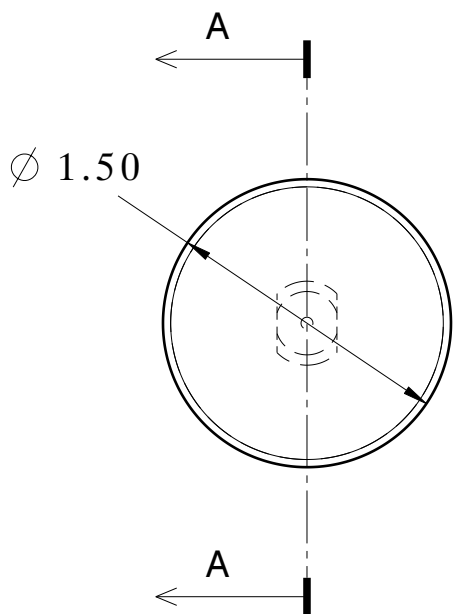
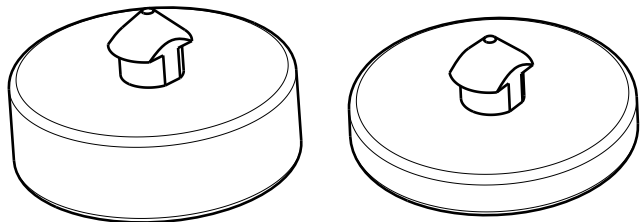

Section view A-A

"A"  
DIM.

.50"

.25"

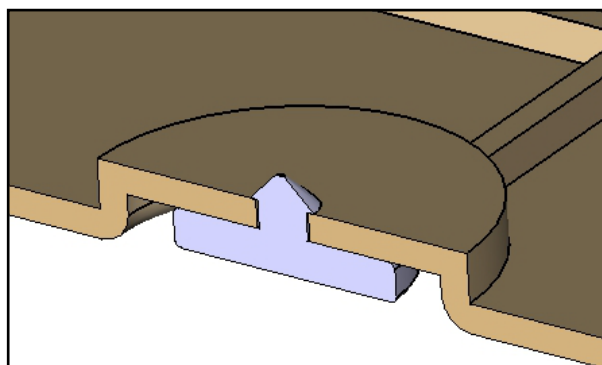
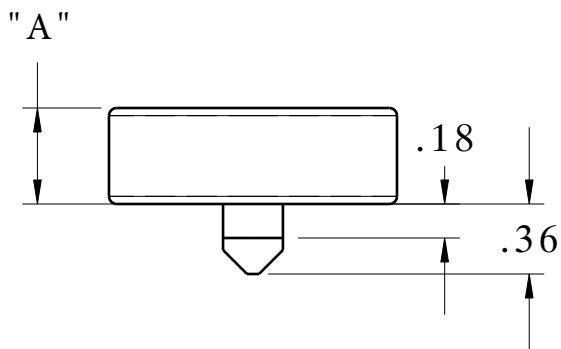

**MATERIAL TYPE**  
Thermoplastic Urethane (TPU)

**HARDNESS**  
95A

**COLOR**  
Gray or Black ( other upon request )

## Anti-Abrasion Button

Applications:

- ANTI-JUMP STOPS
- RESTING PAD FOR SHARP EDGES

**Dunnage  
Engineering**

800-443-5553

www.dunnage-eng.com