

# 38mm Dia. TPU Snap-in Button DE1129

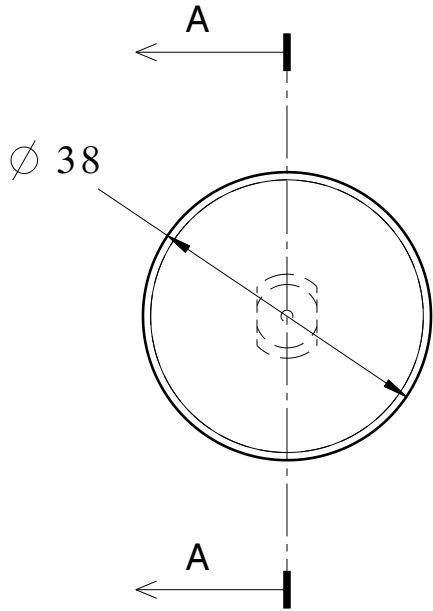

"A"  
DIM. mm

13
6

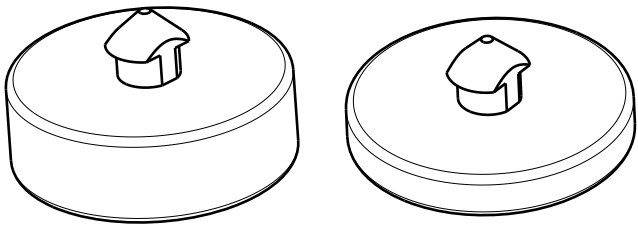
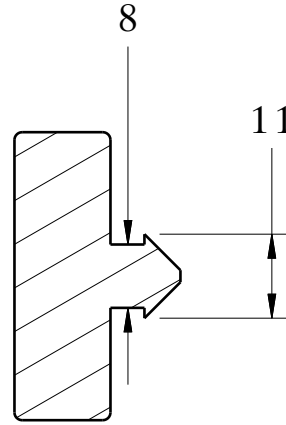

Section view A-A

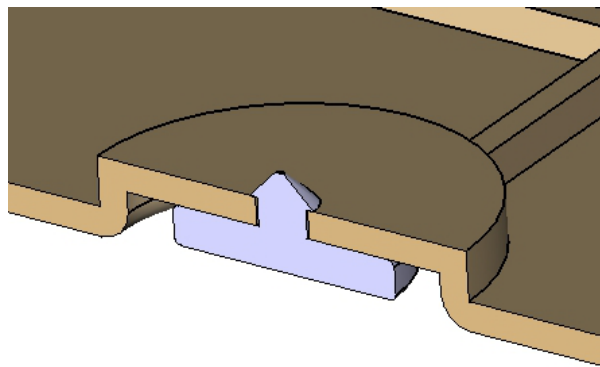
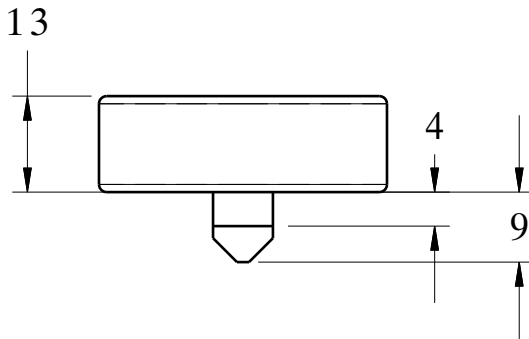

NOTE: All Dimensions are in Millimeters

<b>MATERIAL TYPE</b> Thermoplastic Urethane (TPU)
<b>HARDNESS</b> 95A
<b>COLOR</b> Gray or Black ( other upon request )

## Anti-Abrasion Button

Applications:

- ANTI-JUMP STOPS
- RESTING PAD FOR SHARP EDGES



800-443-5553

www.dunnage-eng.com