

DE515 SEPARATOR DUNNAGE

2.50" INDEX

.12" POCKET

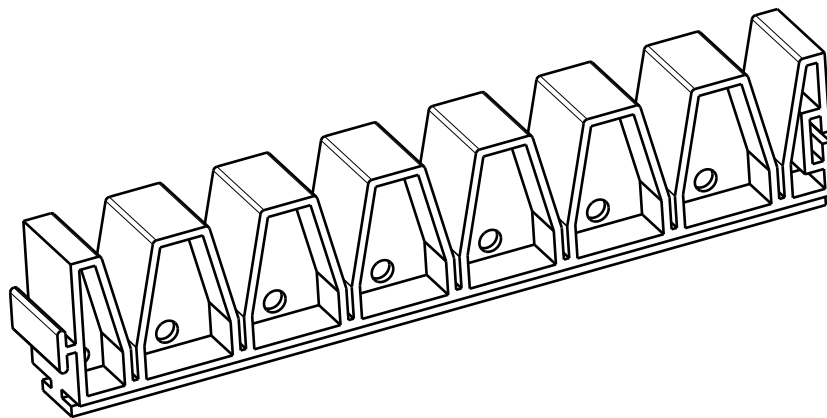
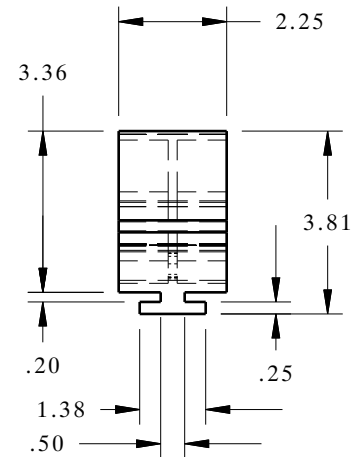
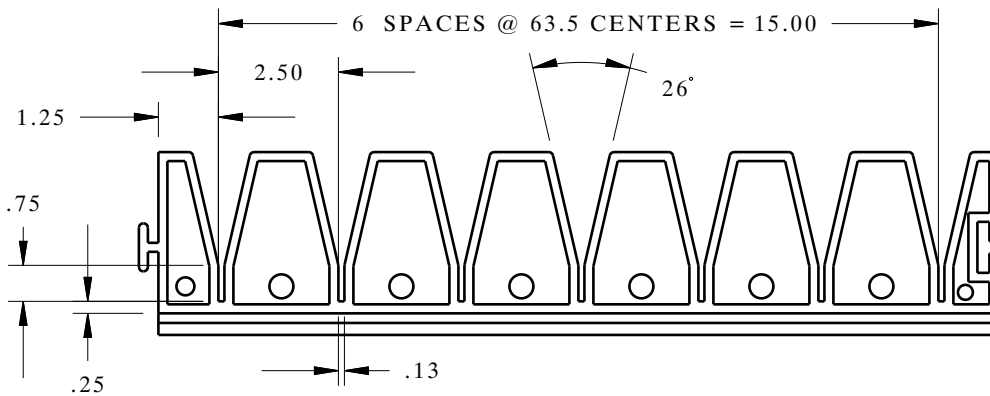
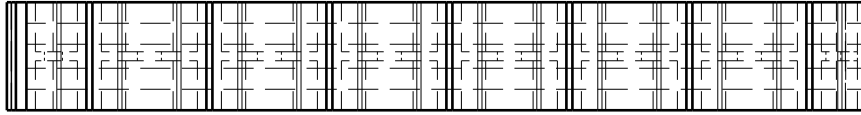

MATERIAL TYPE
Thermoplastic Elastomer (TPE)

HARDNESS (SHORE A)
90 (Standard)

COLOR
Gray, Black, Call

SEPARATOR DUNNAGE
2.50" INDEX, .12" POCKET

Applications:
-Part Separation

 **Dunnage
Engineering**

800-443-5553

www.dunnage-eng.com