

DE569 DUNNAGE BAR STOP

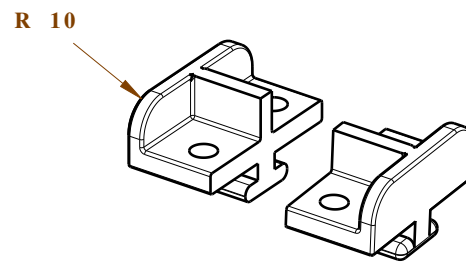
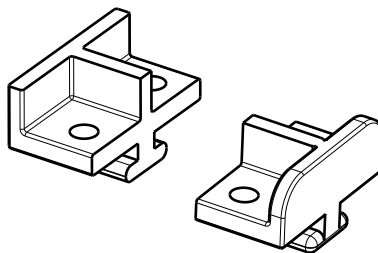
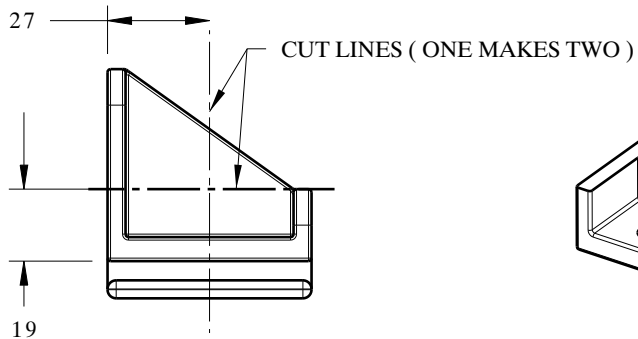
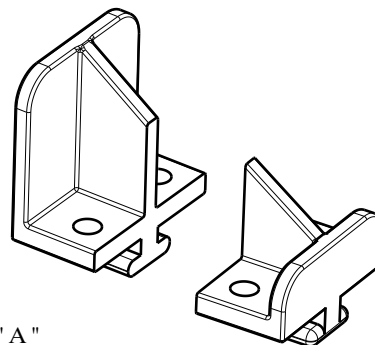
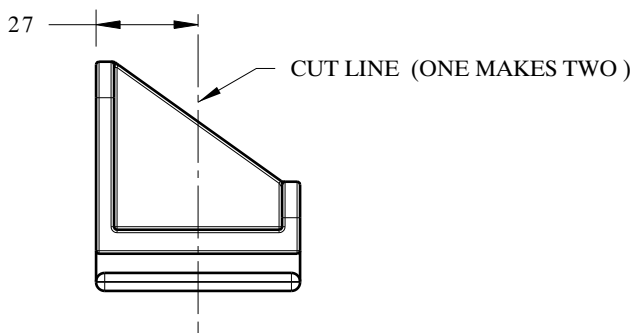
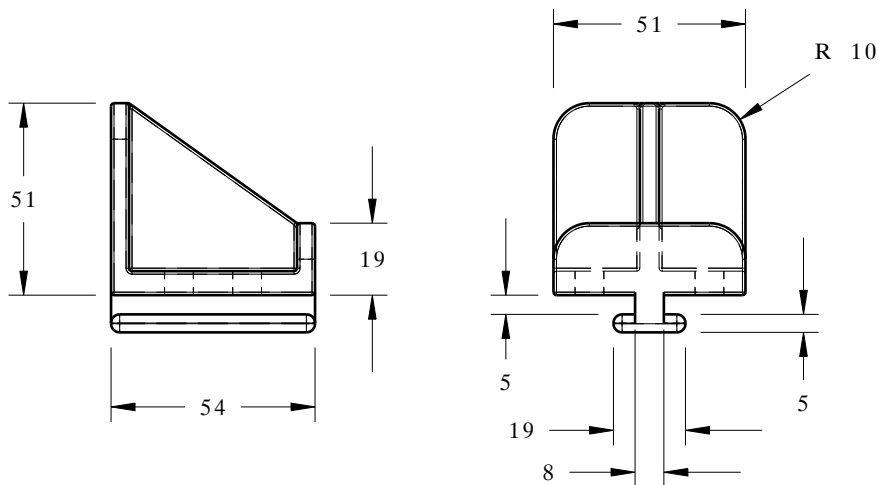
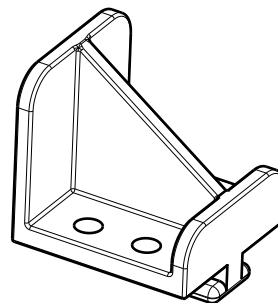
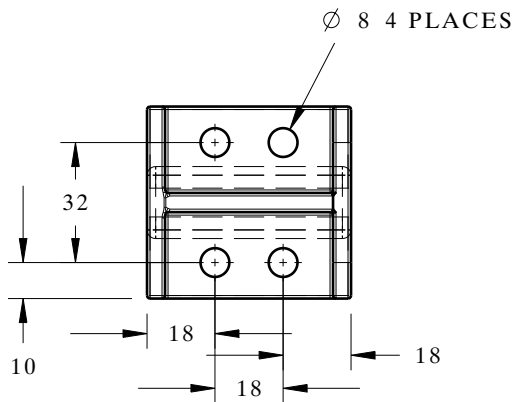

NOTE: All Dimensions are in Millimeters

MATERIAL TYPE
Pulse PC/ABS

HARDNESS (SHORE A)
N / A

COLOR
Black

DUNNAGE BAR STOP

Applications:

-Secure dunnage position when loaded into a slotted channel



800-443-5553

www.dunnage-eng.com