

DE1198-A ANGLE SEPARATOR DUNNAGE
51mm INDEX
13mm POCKET
10 DEG. ANGLE

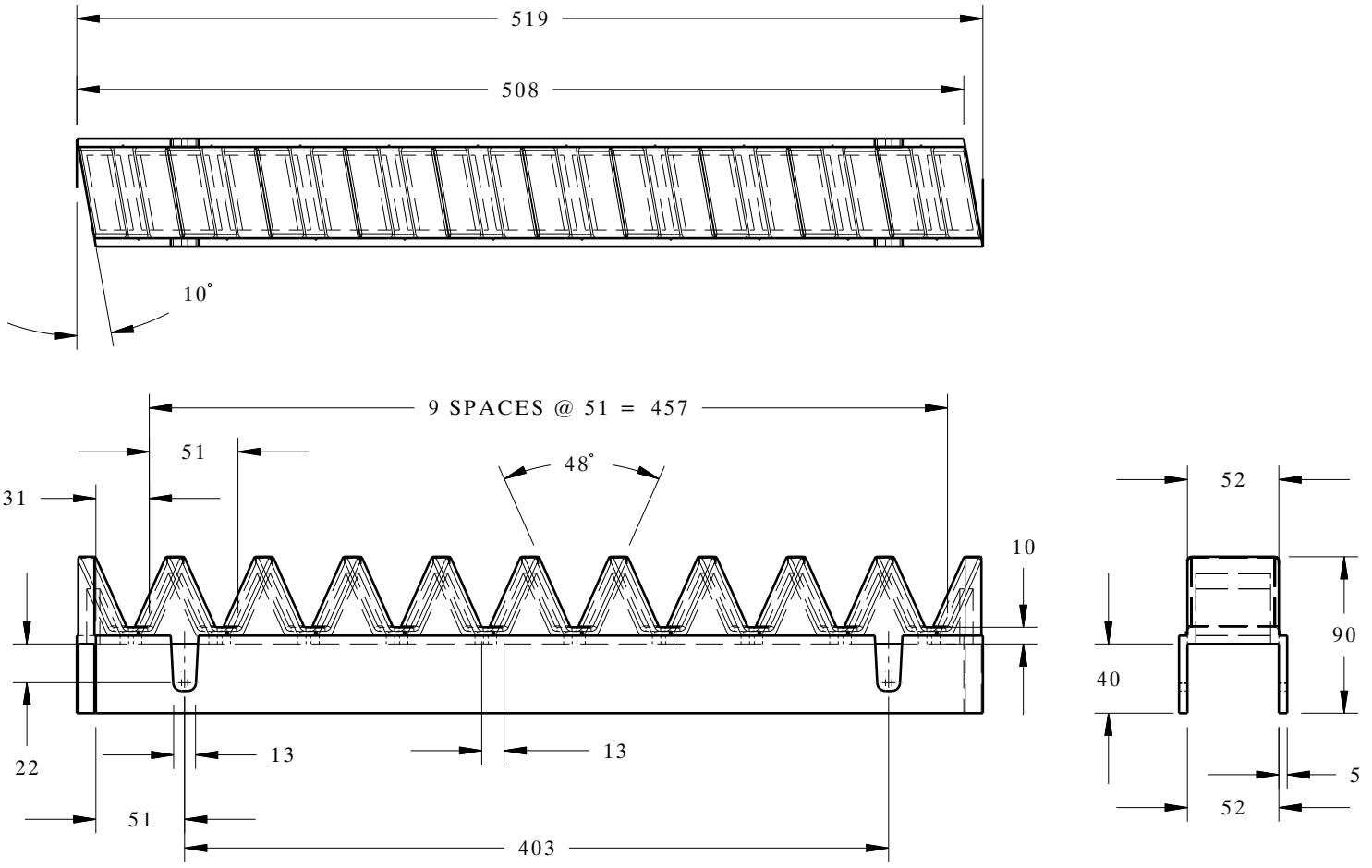

DE1198-A-R (SHOWN)
DE1198-A-L (OPPOSITE)

NOTE: All Dimensions are in Millimeters

MATERIAL TYPE Thermoplastic Elastomer (TPE)
HARDNESS (SHORE A) 90A
COLOR Gray

ANGLE SEPARATOR DUNNAGE
51mm INDEX, 13mm POCKET ,10 DEG.
Applications:
 -Part Separation
 -Side Dunnage - Base Dunnage

Dunnage Engineering
 800-443-5553 www.dunnage-eng.com