

VERTICAL FLIPPER OPTIONS

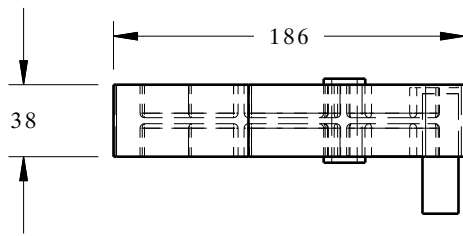

DE1372 FLIPPER
64mm INDEX

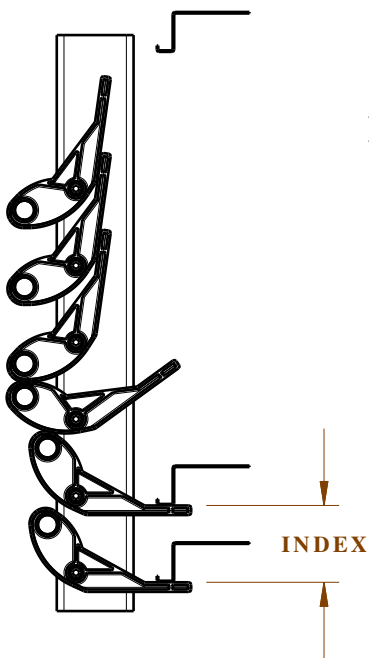
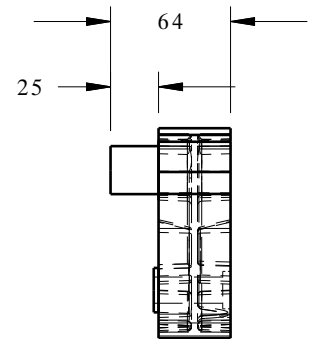
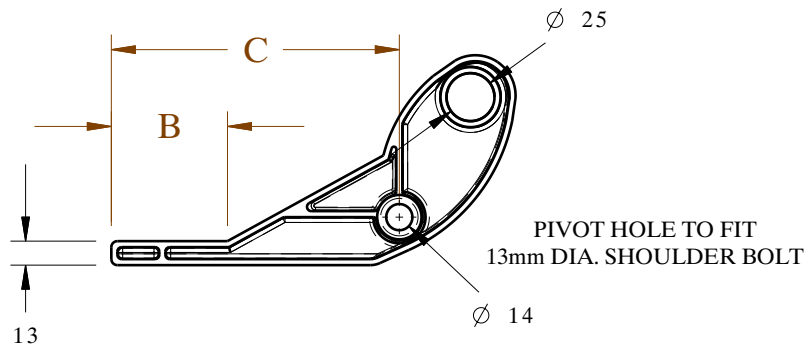
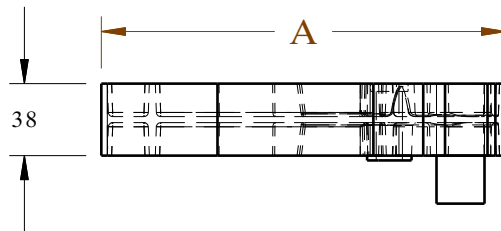
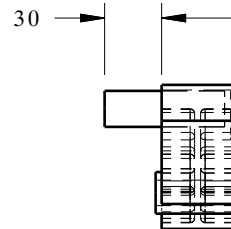
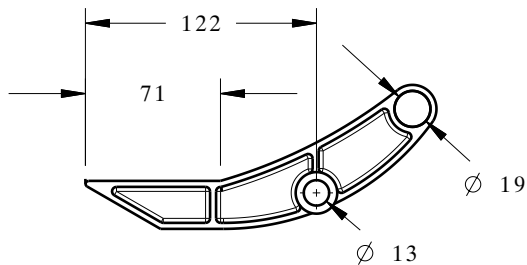

Tool Number	Index	Dim A	Dim B	Dim C
DE1015	76	185	62	127
DE1371 Short	76	185	43	127
DE1371 Long	76	197	56	140
DE740 Short	102	188	36	127
DE740 Long	102	214	61	152
DE1480	102	214	114	153

NOTE : All Dimensions are in Millimeters

MATERIAL TYPE	PC/ PBT
HARDNESS	N/A
COLOR	Black, others upon request

VERTICAL STYLE FLIPPER

Application:

Vertically load and unload panels
in horizontal part orientation



800-443-5553

www.dunnage-eng.com